

OWNER'S MANUAL

MEDIUM DUTY DOOR OPERATOR

MODEL NO.	LDT, LDTB
------------------	-----------

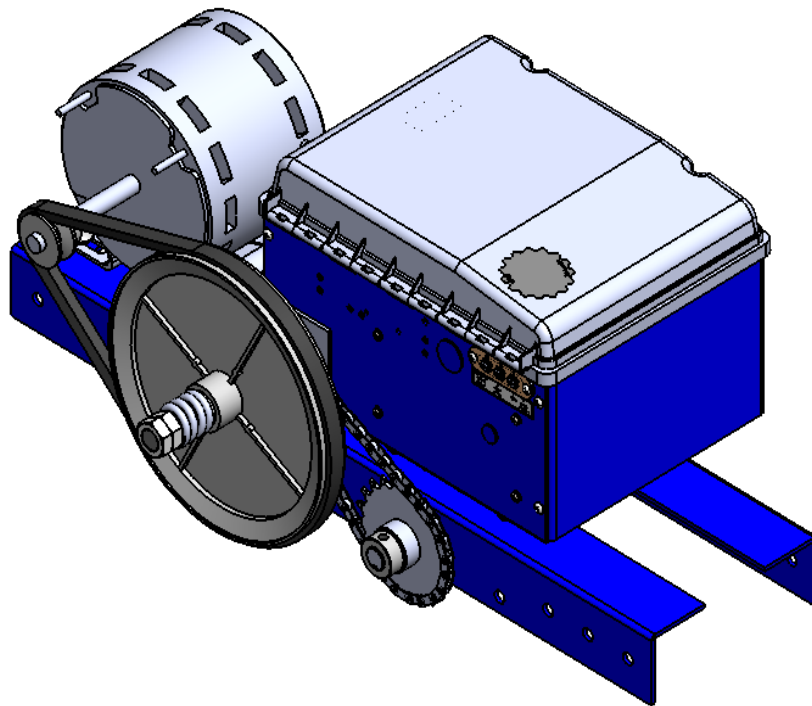

Napoleon/Lynx™

**READ AND FOLLOW ALL INSTALLATION INSTRUCTIONS
SAVE THESE INSTRUCTIONS**

NOT FOR RESIDENTIAL USE

This unit is intended for limited duty applications not to exceed 12 cycles of opening and closing per hour.

SPECIFICATIONS

MOTOR

TYPE:	Intermittent duty
HP:	1/2 HP
SPEED:	1500 RPM
VOLTAGE:	115V 1 Phase 60Hz
CURRENT:	See motor nameplate

ELECTRICAL

TRANSFORMER:	24VAC
CONTROL STATION:	3-button station OPEN/CLOSE/STOP
WIRING TYPE:	B2 (Standard, when powered)
	C2 (When photoeyes are blocked or not present)
LIMIT ADJUST:	Linear driven, fully adjustable screw type cams. Adjustable to 16 feet.

MECHANICAL

DRIVE REDUCTION:	Primary: Heavy duty (4L) V-Belt
	Secondary: #48 chain/sprocket
	Output: #48 chain
OUTPUT SHAFT SPEED:	120 RPM
DOOR SPEED:	Approx. 10" per sec.
BRAKE (Optional):	Solenoid actuated drum brake
BEARINGS:	Ball bearing with hardened races.

SAFETY

DISCONNECT:	Quick disconnect door arm for emergency manual door operation.
PHOTO EYES:	Included with Operator.
REVERSING EDGE:	(Optional) Electric or pneumatic sensing device attached to the bottom edge of door. A REVERSING EDGE IS STRONGLY RECOMMENDED FOR ALL COMMERCIAL OPERATOR INSTALLATIONS. REQUIRED WHEN THE 3 BUTTON CONTROL STATION IS OUT OF SIGHT OF DOOR OR ANY OTHER CONTROL (AUTOMATIC OR MANUAL) IS USED.

DIMENSIONS & WEIGHT

OPERATOR HANGING WEIGHT:	50-60 LBS
DIMENSIONS:	Page 17

⚠ **WARNING**

Improperly operating or an unbalanced door could cause **SERIOUS INJURY or **DEATH**.** See Door Manufacturer's Owner's Manual. Have trained door systems technicians make repairs to cables, spring assemblies, and other hardware.

PREPARATION

Track Assembly

1. Using the center idlers and the front idler, assemble the operator rail by installing the idlers between the rails. Use the hex nuts on the outside and fasten them tight. The front idler should be installed in the second hole. The center idlers should be spaced evenly over the length of the track. (Figure 1)
2. Slide the trolley carriage onto the rail so that the emergency disconnect bracket will be toward the operator.

Operator Attachment

1. Position the track assembly on the frame of the operator so that the motor side is in the back (away from the door).
2. Align the holes in the rail with the holes in the operator and install four 5/16 bolts (two per side).
3. Install hex nuts on the bolts and tighten to secure the operator to the rail.

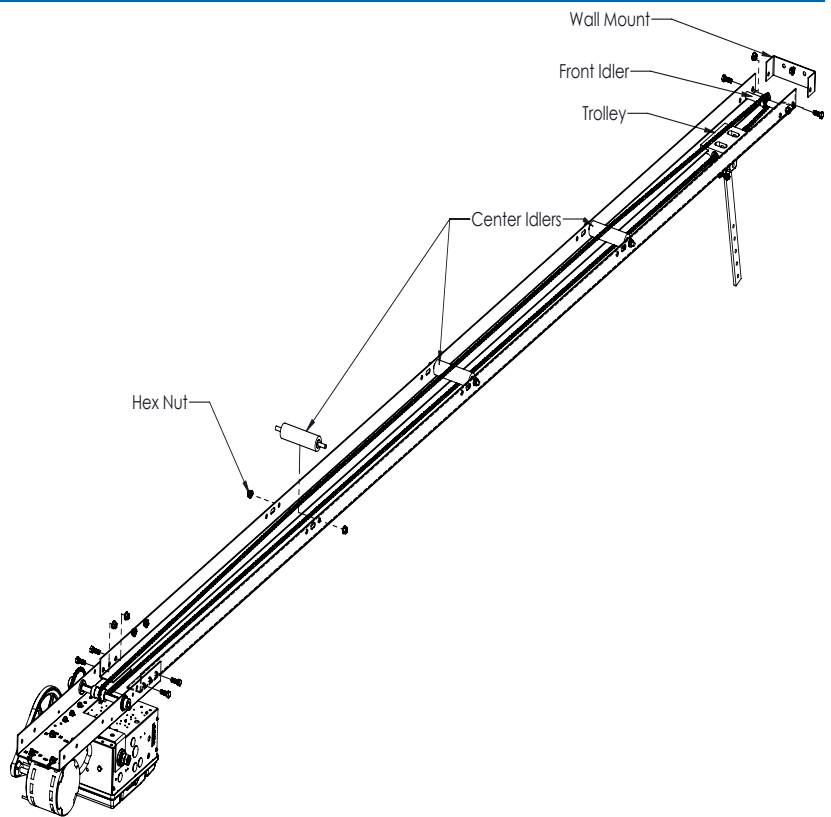

FIGURE 1

Chain Installation

1. With the trolley engaged in the chain tensioner, use a master link to attach one end of the chain to the chain tensioner.
2. Route the chain around the front idler sprocket and the drive sprocket on the operator and back to the other side of the chain tensioner. (Ensure the chain rides across the top of all center idlers present)
3. Connect the free end of the chain to the chain tensioner using another master link.
4. Disengage the chain tensioner from the trolley using the emergency disconnect and slide the trolley out of the way (Figure 2).
5. With the lock nut loose, tighten the chain by turning the main body of the chain tensioner. When desired tension is reached, tighten the lock nut. (If necessary, remove links from the chain to achieve proper adjustment.)

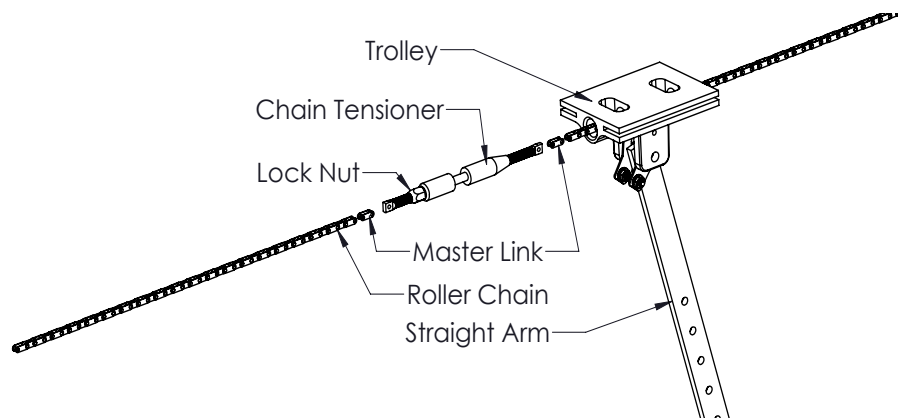

FIGURE 2

INSTALLATION

WARNING



Moving parts on the operator could cause possible **SERIOUS INJURY.** Install the operator at least 8 feet above the floor to keep people away from the moving parts.

IMPORTANT NOTE: Before your operator is installed, be sure the door has been properly aligned, balanced, and is working smoothly.

Mounting Wall Mount

The trolley operator is generally mounted over the center of the door. Some instances require the operator to be off center. If mounting off center refer to the door manufacturing for proper lifting point. (Torsion spring doors may allow off center lifting but Extension spring doors require center lifting.)

1. Mark a vertical line on the header above the door that is centered on the door.
2. Determine the highest point of door travel. Slowly raise the door until the top section reaches its highest point. Use a level to project this line to the header where you marked the center of the door. (Figure 3)
3. Ensure the header is suitable to mount the wall mount to. If necessary, reinforce the wall/header with a mounting pad or suitable mounting brackets.
4. Install the wall mount using suitable hardware. The wall mount should be centered on the vertical line that was drawn and 1"-2" above the line that was drawn from the highest point of door travel.

Mount Operator

1. Raise the front end of the rail assembly to the wall mount and loosely install two 5/16 bolts and nuts to act as pivot points.(Figure 4)
2. Swing the operator to a horizontal position and temporarily secure it with suitable rope, chain, or support from the floor.
3. Tighten the pivot bolts/nuts.
4. Slowly open the door being careful not to disrupt the temporary support.
5. With the door fully open, place a level on top of the rail and use shims across the top section of the door to support the track assembly in a horizontal position.(Figure 5)

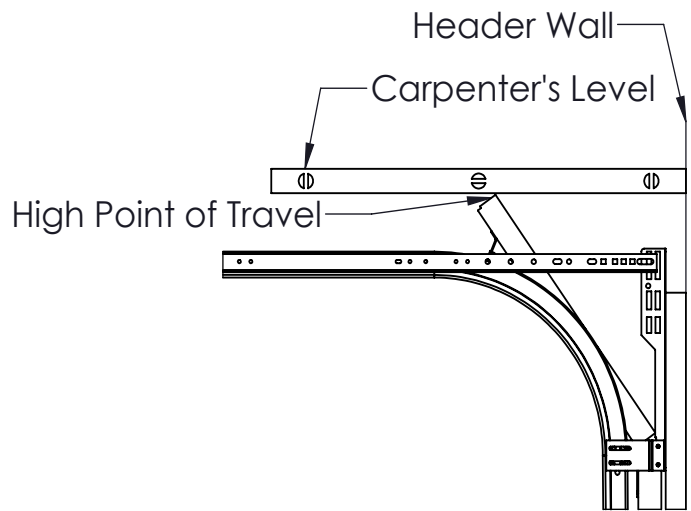

FIGURE 3

IMPORTANT NOTE: To aid installation, see page 17 (Shop Drawing) for mounting consideration.

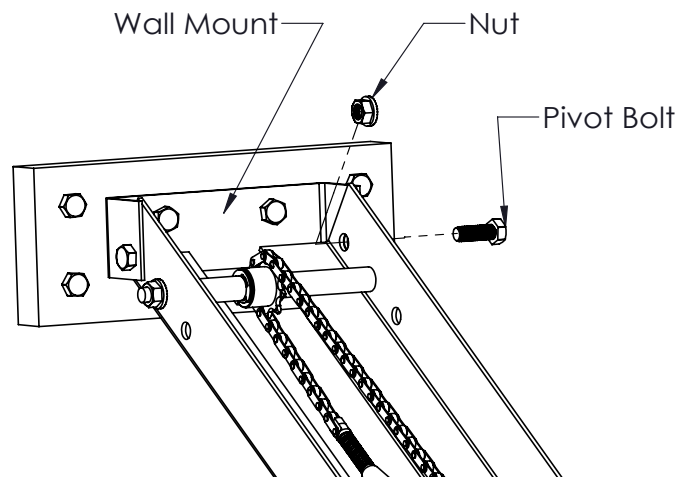

FIGURE 4

INSTALLATION

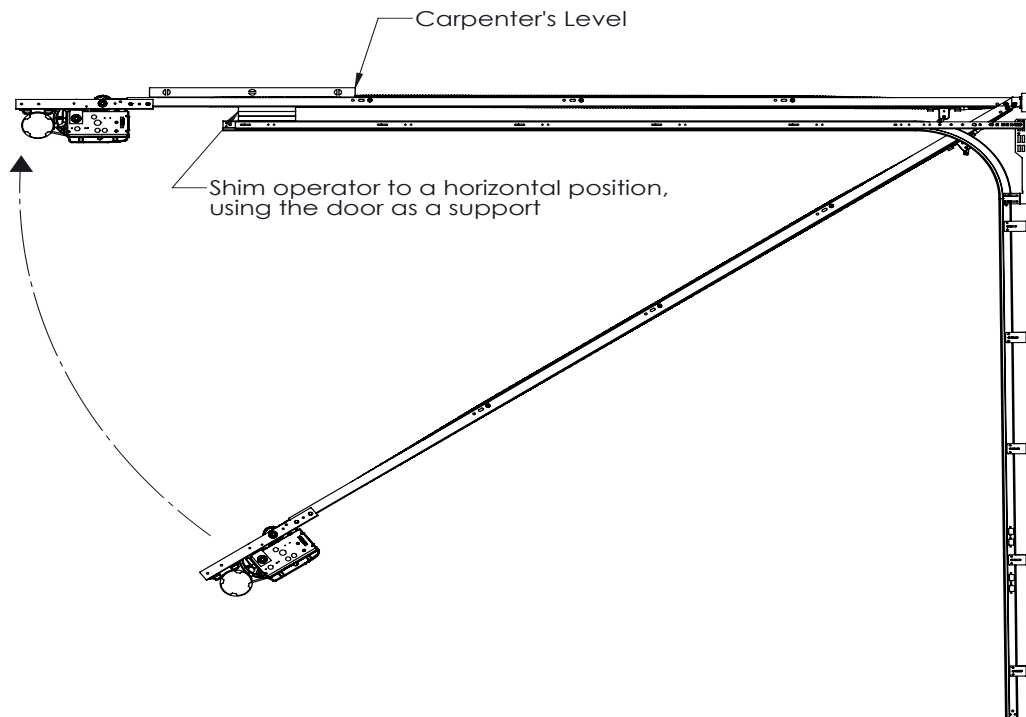

FIGURE 5

Hang the Operator

1. The illustration shows a typical method of hanging the operator from the ceiling. Each installation may vary, but in all cases side braces should be used for additional strength.
2. Clearance holes are provided on both sides of the operator for mounting the support braces.
3. With the rail in line with the wall mount, install the appropriate support bracing. (If the track is longer than 15' a middle support brace is recommended). (Figure 6)

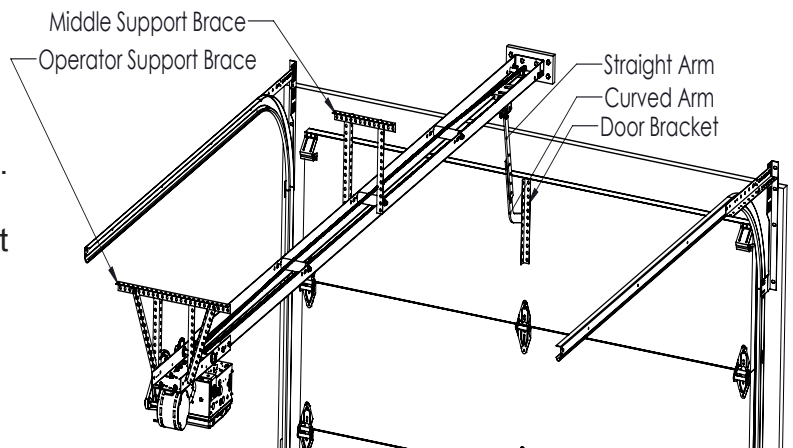

FIGURE 6

NOTE: At this time, ensure all bolts and lags are properly secured.

Door Attachment

1. Fully close the door.
2. Install the door bracket to the top section of the door and in-line with the rail using suitable hardware. Many installations, except solid wood doors, will require additional support for the door. Refer to illustration. (Figure 6)
3. Install the bottom hole of the curved arm to the door bracket using a 3/8-16 bolt, 3/8 lock nut, and two 3/8 washers (tighten only enough to still allow arm to pivot.) The pivot bolt should be closely in-line with the top rollers.
4. Slide the trolley so that the straight arm and curved arms holes line up. Use 5/16 bolts and nuts to fasten the two arms tightly together. (The straight arm should angle away from the door 15-45 degrees)

MANUAL OPERATION

⚠ WARNING

⚡ Moving chain could cause possible **SERIOUS INJURY**. DISCONNECT electric power to the operator **BEFORE** manually operating your door

⚠

This operator has provisions for manually operating the door in case of emergency or power failure.

Emergency Disconnect System

1. To Disconnect Door From Operator : The door should be fully closed if possible. Pull down and away from the door on the emergency release knob. (Figure 7) Make sure the disconnect snaps back in the released position to prevent the trolley from reconnection automatically. The trolley will release from the chain tensioner. The door can now be raised and lowered manually.

2. To Reconnect Door to Operator : Pull the emergency release knob toward the door so that the disconnect snaps to the engaged position. The next time the chain tensioner slides through the trolley, the trolley will reconnect with it.

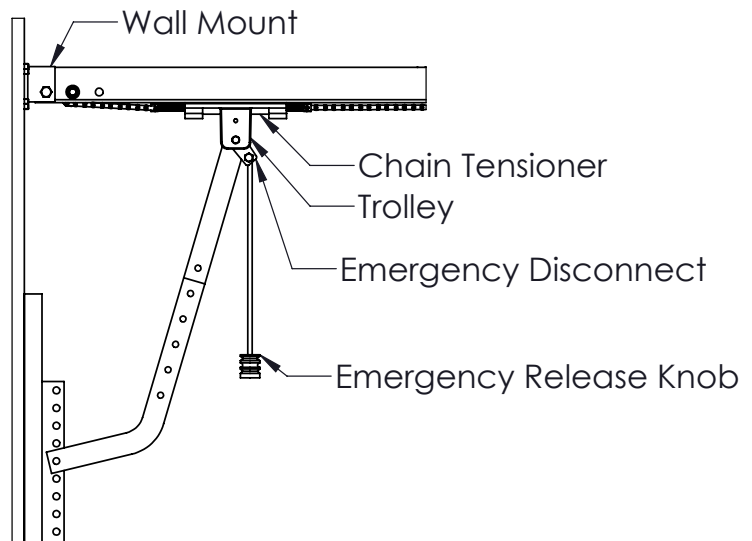

FIGURE 7

⚠ WARNING

⚡ To prevent **SERIOUS INJURY** or **DEATH:**

- DO NOT connect electric power until instructed to do so.
- ALWAYS call a trained professional door serviceman if door binds, sticks or is out of balance. An unbalanced door may not reverse when required.
- NEVER try to loosen, move or adjust doors, door springs, cables, pulleys, brackets or their hardware, ALL of which are under **EXTREME** tension and can cause **SERIOUS PERSONAL INJURY**.
- DISABLE ALL locks and remove ALL ropes connected to door **BEFORE** installing and operating door operator to avoid entanglement.

⚠

ENTRAPMENT PROTECTION ACCESSORIES (OPTIONAL)

SENSING EDGES

All types of sensing edges with an isolated normally open (N.O.) output are compatible with your operator. This includes pneumatic and electric edges. If your door does not have a bottom sensing edge and you wish to purchase one, contact the supplier of your operator.

If not pre-installed by the door manufacturer, mount the sensing edge on the door according to the instructions provided with the edge. The sensing edge may be electrically connected by either coiled cord or take-up reel.

IMPORTANT NOTES:

- a. Proceed with Limit Switch adjustments before making any sensing edge wiring connections to operator as described below.
- b. Electrician must hardwire the junction box to the operator electrical box in accordance with local codes.

WARNING



To reduce risk of **SEVERE INJURY or DEATH**, ALWAYS install reversing sensors when the 3-button control station is out of sight of door or ANY other control (automatic or manual) is used. Reversing devices are recommended for all installations.

WIRING: For wiring of your sensing device to the operator, refer to the wiring diagram supplied with your operator. See field connection terminals identified as Safety Device.

TAKE-UP REEL: Take-up reel should be installed 12" above the top of the door.

COIL CORD: Connect operator end of coil cord to junction box (not supplied) fastened to the wall approximately halfway up the door opening.

LIMIT SWITCH ADJUSTMENT

WARNING



To avoid **SERIOUS PERSONAL INJURY or DEATH from electrocution**, disconnect electric power **BEFORE** manually moving limit nuts.

IMPORTANT NOTE: Make sure the limit nuts are positioned between the limit switch actuators before proceeding with adjustments.

1. To adjust limit nuts depress retaining plate to allow nut to spin freely. After adjustment, release plate and ensure it seats fully in slots of both nuts.
2. To increase door travel, spin nut away from actuator. To decrease door travel, spin limit nut toward actuator.
3. Adjust open limit nut so that door will stop in open position with the bottom of the door even with top of door opening.
4. Repeat Steps 1 and 2 for close cycle. Adjust close limit nut so that actuator is engaged as door fully seats at the floor. (Figure 8)

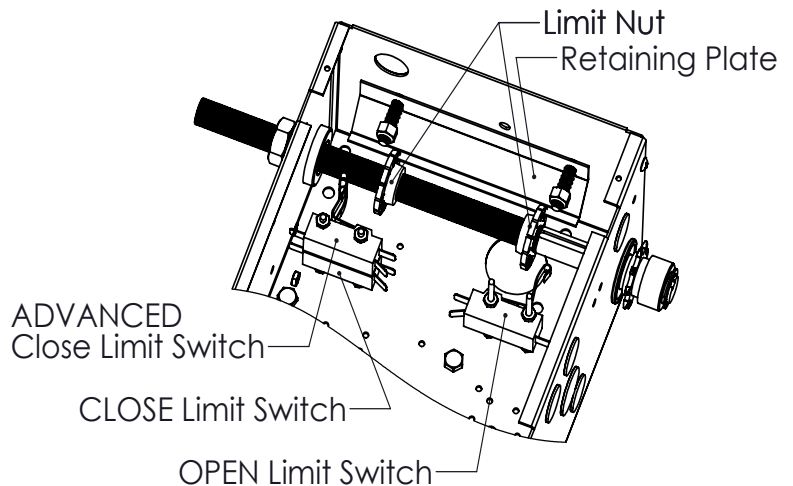

FIGURE 8

POWER WIRING

WARNING



To reduce the risk of SEVERE INJURY or DEATH:

- ANY maintenance to the operator or in the area near the operator **MUST NOT** be performed until disconnecting the electrical power and locking-out the power via the operator power switch. Upon completion of maintenance the area **MUST** be cleared and secured, at that time the unit may be returned to service.
- **DISCONNECT** power at the fuse box **BEFORE** proceeding. Operator **MUST** be properly grounded and connected in accordance with local electrical codes. The operator should be on a separate fused line of adequate capacity.
- ALL electrical connections **MUST** be made by a qualified individual.
- **DO NOT** install ANY wiring or attempt to run the operator without consulting the wiring diagram. We recommend that you install an optional reversing edge **BEFORE** proceeding with the control station installation.
- ALL power wiring should be on a dedicated circuit and well protected. The location of the power disconnect should be visible and clearly labeled.
- ALL power and control wiring must be run in separate conduit.
- To avoid damage to door and operator, make ALL door locks inoperative. Secure lock(s) in "OPEN" position. If the door lock needs to remain functional, install an interlock switch.



POWER WIRING CONNECTIONS

1. DO NOT INSTALL ANY WIRING WITHOUT CONSULTING THE WIRING DIAGRAM.

The wiring diagram is included in this manual (page 15).

2. Be sure the power being supplied is of the correct voltage, phase, frequency, and amperage in accordance with the operator's serial tag.
3. Using a conduit access hole as shown below, bring supply lines to the operator and connect wires to the terminals indicated on the wiring diagram.
4. Important NOTE: Connect earth ground to the chassis ground screw in the electrical box enclosure. Do not turn power on until you have finished making all power and control wiring connections and have completed the limit switch adjustment procedure.

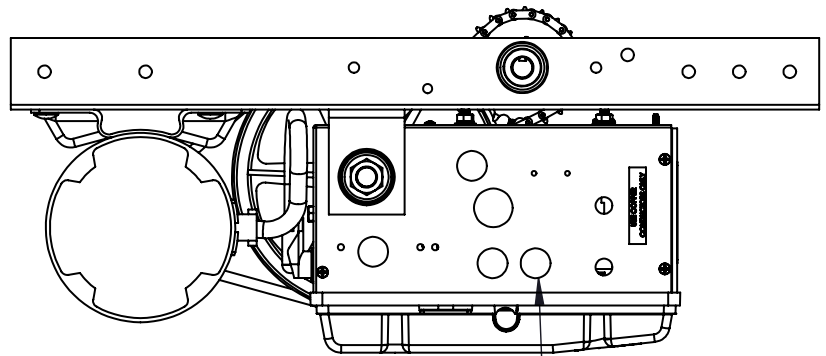

(5) 7/8" & (1) 1-3/16" Dia.
Knockouts for Power &
Control Wiring access
(Near & Opposite side)

FIGURE 9

CONTROL WIRING

WIRING TYPE

LDT and LDTB models are equipped with the LX900 board (programming and operation, page 12, field wiring, page 16). Upon installation the operator will be in C2 mode (which means only constant pressure will close the door).

To achieve B2 mode (where a momentary contact can be used to close the door) an entrapment protection device must be wired into the beam terminals according to the wiring diagram. Once the LX900 detects there is no obstruction it will switch to B2 Mode.

CONTROL STATION LOCATION

All operators are supplied with some type of control station. Generally a three button station (OPEN/CLOSED/STOP) is provided. Mount the control station within sight of the door, at a minimum of five (5) feet above the floor so small children cannot reach it, and away from all moving parts of the door.

RADIO CONTROL

All LDT series operators have internal antenna's. LX900 compatible Single button, three button, or OPEN/CLOSE/STOP (OCS) transmitter(s) are optional accessories. While in B2 Mode, transmitters will operate the door the same as a wall control station. Also on all LDT series operators, terminal strip is provided on the side of the electrical enclosure labeled as a 24 Volt Class 2 circuit and numbered (1,2,3). All standard radio receivers may be wired to this terminal strip. Single channel transmitters will then open a fully closed door, close a fully open door, and reverse a closing door from the radio transmitter. However, for complete door control from a remote, a commercial three-channel radio receiver (with connections for OPEN/CLOSE/STOP) is recommended.

ADDITIONAL ACCESS CONTROL EQUIPMENT

Locate any additional access control equipment as desired (but so that the door will be in clear sight of the person operating the equipment), and connect to the control board in accordance with the LX900 WIRING CONNECTIONS diagram. Any control with a normally open (N.O.) isolated output contact may be connected in parallel with the OPEN button or to the momentary switch terminals. More than one device may be connected in this manner. Use 18 gauge wire or larger for all controls.

External Interlock Switch

If an external interlock switch is required on the door, refer to the LX900 WIRING CONNECTIONS diagram for installation. This switch should have a contact rating of at least 3 amps @ 24VAC. The switch must be wired in series with the STOP or COM terminals so that the door will only operate while the switch is in its closed circuit state.

WARNING



To prevent possible **SERIOUS INJURY** or **DEATH**:

- Install the control station within sight of the door at a minimum of five (5) feet (to prevent operation by children), but away from the door and its hardware.
- Install reversing sensors when the 3-button control station is out of sight of the door or ANY other control (automatic or manual) is used. Reversing devices are recommended for ALL installations
- A reversing edge **MUST** be installed when a receiver is used to activate a commercial door opener.

IMPORTANT NOTE:

Mount warning notice beside or below the push button station.



WARNING



To prevent possible **SERIOUS INJURY** or **DEATH** from a moving garage door:

- ALWAYS keep remote controls out of reach of children.
- NEVER permit children to operate, or play with remote controls.
- Activate gate or door **ONLY** when it can be seen clearly, is properly adjusted, and there are no obstructions to door travel.
- ALWAYS keep gate or garage door in sight until completely closed. NEVER permit anyone to cross path of moving gate or door.

PHOTO EYE INSTALLATION

PHOTO EYE INSTALLATION

1. Make sure that power is disconnected to the system prior to installing the photo eyes.
2. Photo eyes need to be mounted inside the building. They should be mounted on either side of the door and as close as possible to the door track to offer maximum safety precaution.
3. Photo eyes should be mounted no more than 6 inches from the floor. Both brackets need to be installed at the same height to allow them to align.
4. Select a mounting location 5 inches above the floor to the centerline of the wall mounting “L” bracket. Mount the bracket to the wall. Repeat this step on the opposite side of the door.
5. Using the wing nuts provided, attach the photo eyes to the “L” brackets with the arrows pointing up. Do not over tighten.

IMPORTANT NOTE:

Identify which side of the garage door is exposed to the most sunlight. Mount the sending unit (TX) on the side that is exposed to the most sun. Sunlight may affect the photo sensors and this orientation will help reduce the effect.

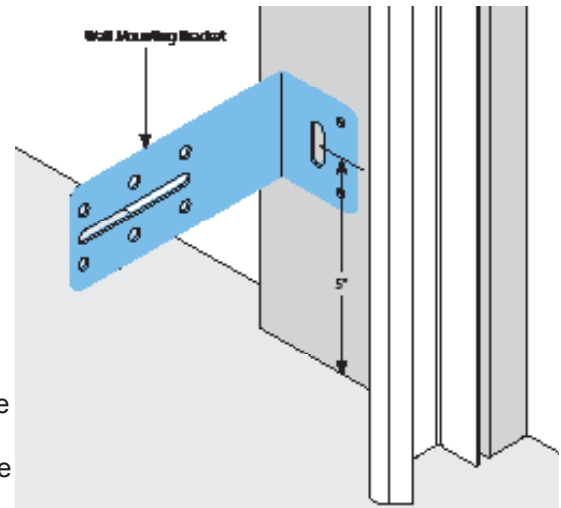

FIGURE 10

6. The transmitter and the receiver both have two 22-gauge wires coming from them. Uncoil the wires from the photo eyes and route them to the controller. Take one wire from the transmitter and one wire from the receiver (these wires have no polarity) and twist the stripped ends together. Repeat on the second wire from each unit. Connect the wires to the BEAM terminals. Again, polarity is not important.
7. At this time, you can reconnect the power to the operator. The LEDs on both transmitter and receiver will be lit if installed and aligned properly; the transmitter has a red LED, and the receiver has a green LED.
8. If the photo eyes are not aligned, then the green LED on the receiver will be off. To align the photo eyes, you can adjust the position of the transmitter or the receiver on the slot of the bracket until both LEDs are lit. Tighten the brackets.
9. To test the photo eye system: open the door to the full open position. Close the door and as the door is closing, obstruct the beam. The door should stop and reverse to open.
10. Test the photo eye's function periodically.

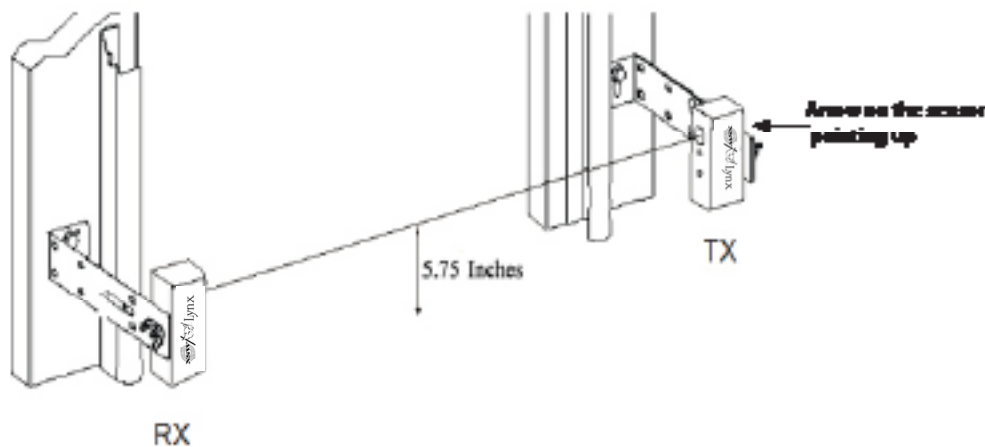

FIGURE 11

LX900 PROGRAMMING AND OPERATION

WARNING



To reduce the risk of serious injury or death, follow these instructions carefully:

- Read and follow ALL instructions.
- Keep fingers and other body parts away from all moving parts of the door and gate operator system while it is being operated.
- Keep the radio controls away from children. Do not allow children to play with the controls.
- Keep away from the door when it is in motion. Watch the door while it is moving until completely closed or opened.
- Do not cross the path of a moving door.
- Disable and locks and remove any ropes connected to the garage door to avoid entanglement and prevent damage to the system.
- Do not make repairs to cable, springs, or other hardware; call a trained door systems technician. The system is under extreme tension and can cause serious injury or death.
- Ensure that the door is properly operating and balanced. If not, call a trained door systems technician to make repairs.



MODES OF OPERATION

This controller has three (3) different modes of operation B2, C2, and TS (Timer Secure). Factory default is B2 mode and the Timer To Close (TTC) is 0 seconds. Anytime the operator does not detect safety beams, it will automatically change to C2 mode. If the TTC is larger than 0 seconds, it will automatically change to TS mode. There are 7 fixed delays for TTC – 3, 15, 30, 45, 60, 90 and 180 seconds. To adjust the setting, hold in the TTC button (refer to diagram). Three LED's above the TTC button will indicate the current setting on the adjacent chart. After reaching 180 seconds, it will jump back to 0 seconds (default) and the operator will revert to B2 Mode.

C2 Mode

- Momentary press of OPEN will open door.
- Constant pressure required on CLOSE for the door to close.
- Single or three button transmitter will open or stop the door only.

B2 Mode

- Momentary press of OPEN or CLOSE will activate door.
- Single button - reverses a closing door, stops an opening door.
- Transmitters activate operator same as wall stations.

TS Mode

- Button function is the same as B2 mode.
- Includes Timer to Close (TTC) function. The door will automatically close after set time expires. Timer starts when door reaches the open limit. (When first entering TS mode or after power interruption, momentary press of OPEN will start timer if door is at OPEN limit.)

General Notes regarding Mode of Operations:

- After power interruption the first move is Open.
- STOP button works in all modes of operation. If the 3 button wall station is not connected to the Control board or there is no jumper between COM and STOP, the motor will not run.
- The Constant Pressure (CP) feature will work only from 3 and 1 button wired Wall Stations
- The controller includes a Run Timer: a maximum amount of time the motor will run after receiving either open or close command. Factory default: 45 seconds. Not adjustable.
- Open override means that the door may be reversed while closing by activating an OPEN button without the need to use the STOP button first (for all 3 Modes).

LX900 PROGRAMMING AND OPERATION

Programming a transmitter: To program a remote transmitter, press and hold the LEARN button for 3 seconds, the learn LED will turn ON and the operator will stay at LEARN mode for 15 seconds only. While in LEARN mode, press (any) button on the transmitter and notice that the LEARN LED will flash four (4) times, indicating that the transmitter has been programmed to the operator. The controller will learn up to 20 Lynx transmitters.

Erase all transmitters: To erase all remote transmitters, press and hold the LEARN button for at least 15 seconds. During this time observe that the learn LED will turn ON and, after about 10 seconds the LEARN LED will flash three (3) times indicating that all the transmitters have been erased from the operator.

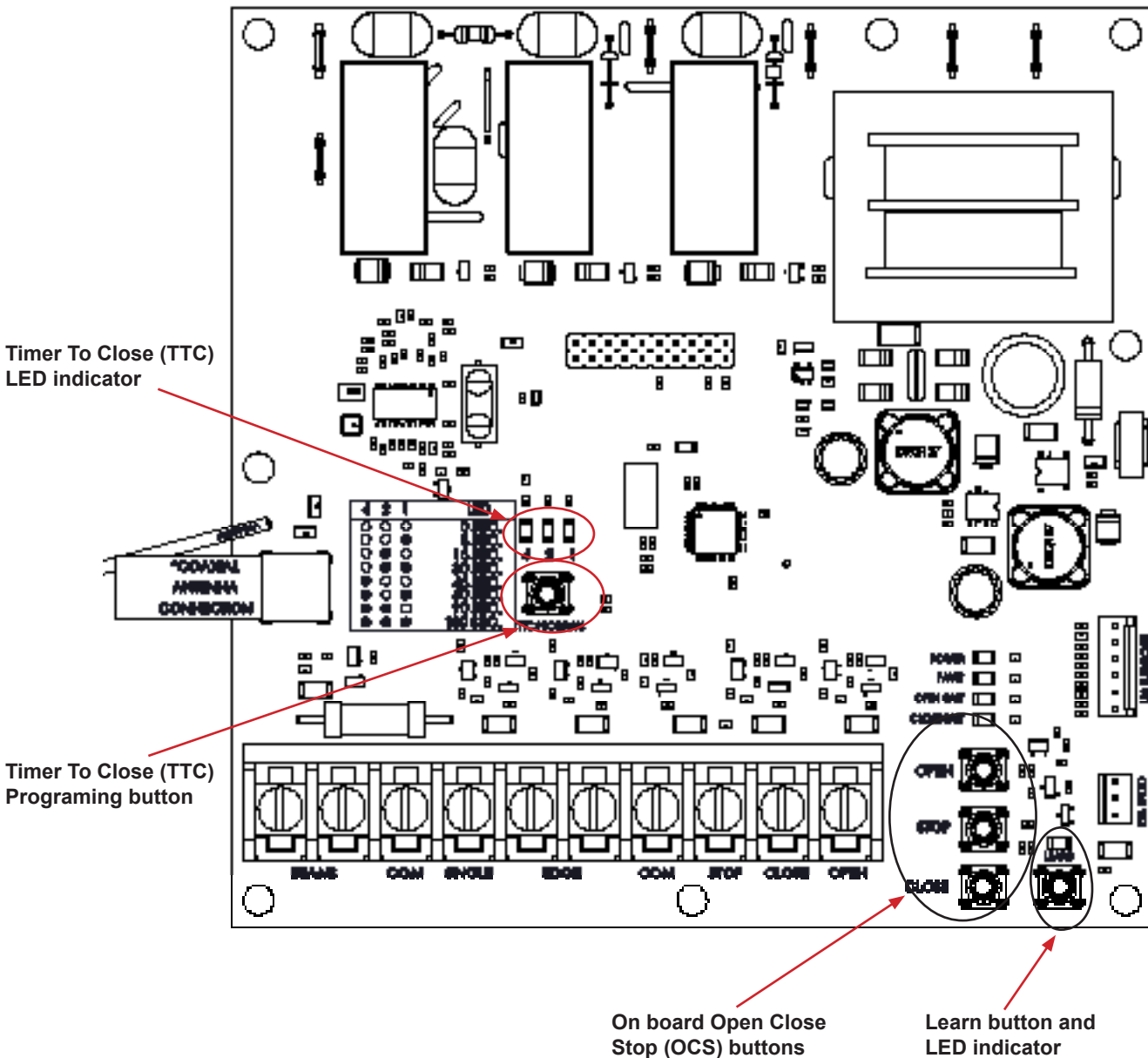

FIGURE 12

CLUTCH ADJUSTMENT

1. Loosen the adjustment jam nuts until there is little tension on the clutch spring.
2. Tighten the inner jam nut gradually until there is just enough tension to permit the operator to move the door smoothly but to allow the clutch to slip if the door is obstructed. When the clutch is properly adjusted, it should generally be possible to stop the door by hand during travel.
3. Tighten the outer jam nut and lock the nuts in place by tightening them against one another.

IMPORTANT NOTE:

The adjustable friction clutch is NOT an automatic reversing device.

⚠ WARNING

To prevent possible SERIOUS INJURY or DEATH, install reversing sensors when the 3-button control station is out of sight of the door or any other control (automatic or manual) is used. Reversing devices are recommended for ALL installations.

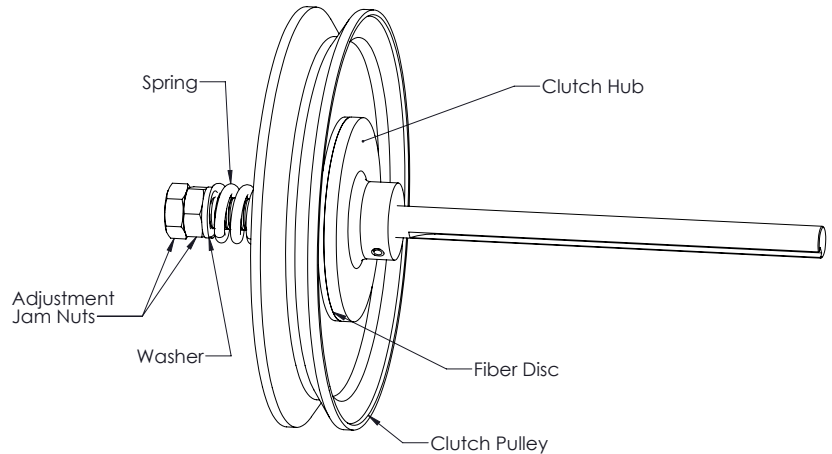

BRAKE ADJUSTMENT

On model LDTB, a brake is supplied from the factory. It is designed to stop and hold the door in position whenever power is removed from the motor.

On first installation the brake should not need adjustment. The brake operation should be inspected every 3 months. As the brake pads wear, adjustments need to be made to maintain proper operation.

With the power disconnected to the operator, carefully try to rotate the large drive pulley by hand. The brake should be engaged and it should be very difficult to turn.

While pushing the solenoid plunger in by hand, there should now be clearance between the brake pads and the drum (approximately .020") allowing the pulley to rotate freely. To achieve the proper operation, adjust the upper and lower pad spacing bolts (A&B) accordingly.

⚠ WARNING

To avoid SERIOUS PERSONAL INJURY or DEATH from electrocution, DISCONNECT electric power BEFORE performing any maintenance

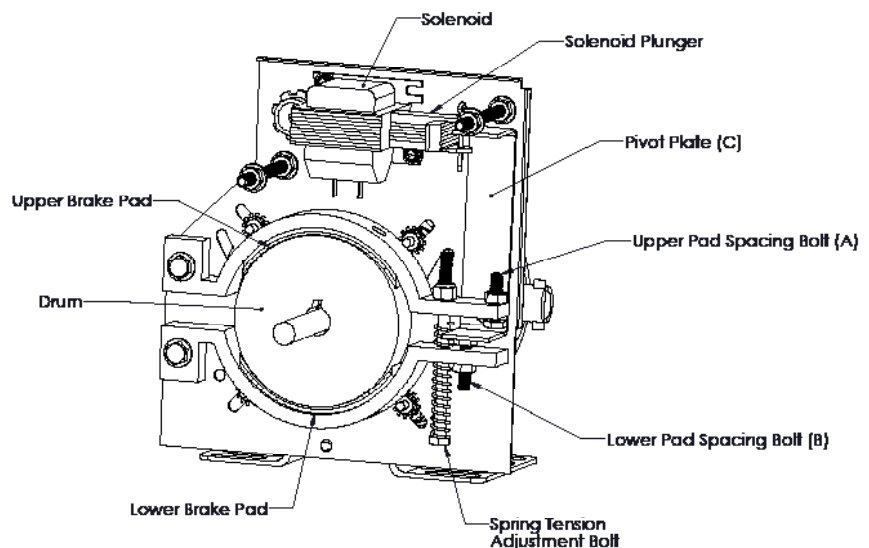

TESTING THE SYSTEM

Turn on the power to the operator. Test all controls and safety devices to make sure they are working properly. Refer to the previous instructions in this manual to make necessary adjustments.

IMPORTANT NOTE:

Do not leave operator power on unless all safety and entrapment devices have been tested and are working properly. Be sure you have read and understand all Safety Instructions in this manual.

IMPORTANT NOTE:

Be sure the owner or person(s) responsible for the operation of the door have read and understand the Safety Instructions, know how to electrically operate the door in a safe manner, and know how to use the manual disconnect operation of the door system.

MAINTENANCE SCHEDULE

IMPORTANT NOTE:

Do not...

- Use grease or silicone spray
- Lubricate motor
- Lubricate Clutch or V-belt

Do...

- Disconnect ALL electric power BEFORE performing any maintenance.
- Use SAE 30 Oil.
- Inspect and service whenever a malfunction is observed or suspected.



WARNING



To avoid **SERIOUS PERSONAL INJURY or DEATH** from **electrocution**, disconnect ALL electric power BEFORE performing ANY maintenance.

ITEM	PROCEDURE	EVERY 3 MONTHS	EVERY 6 MONTHS
Drive Chain	Check for excessive slack, adjust as needed.	●	
	Lubricate.	●	
Sprockets	Check for set screw tightness.	●	
Clutch	Check, adjust as needed.		●
Belt	Check condition & tightness.		●
Fasteners	Check, tighten if needed.		●
Manual Disconnect	Check & operate.		●
Brake (if present)	Check, adjust as needed.	●	

WIRING DIAGRAM (FACTORY)

LDT

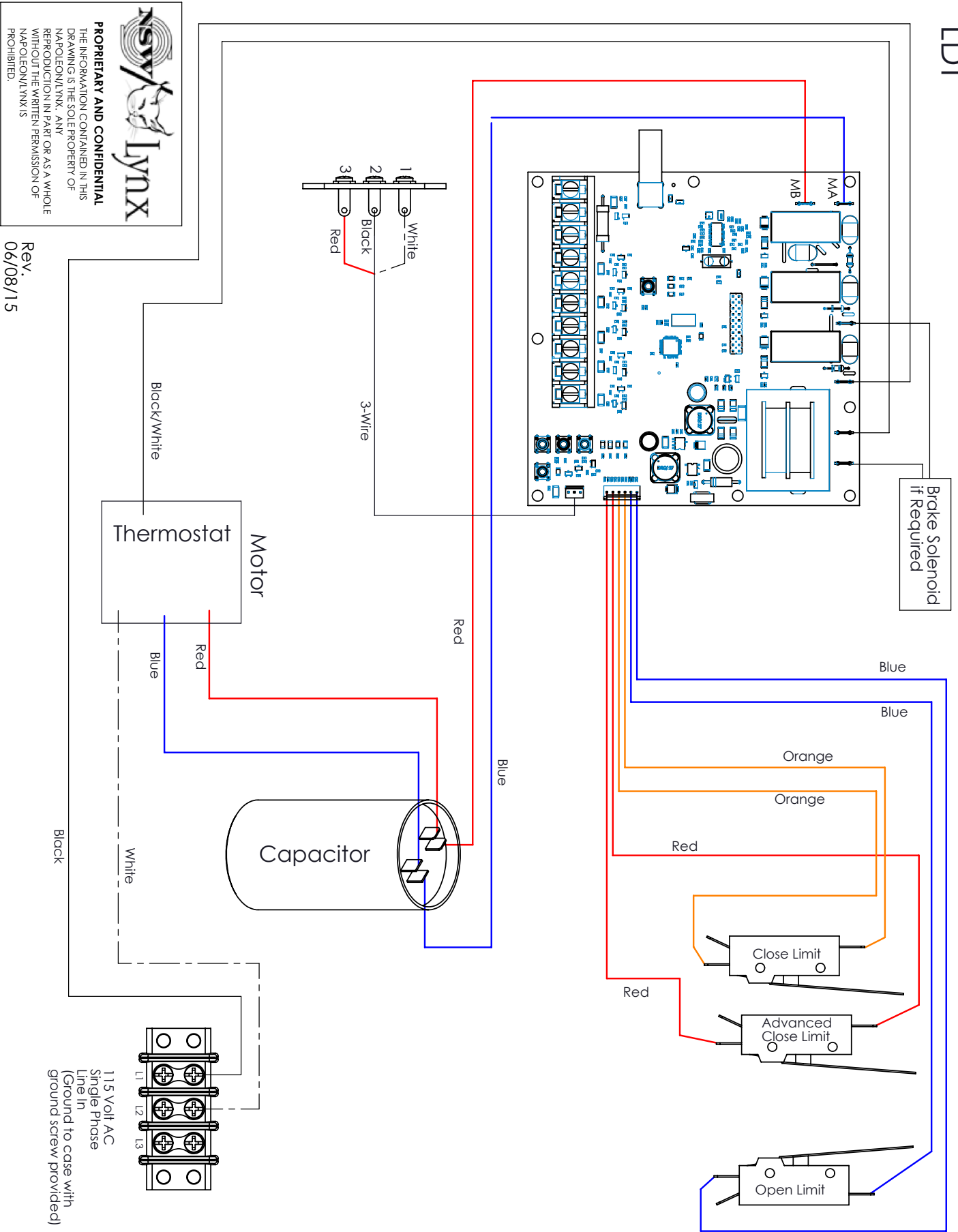

NSV/LYNX
PROPRIETARY AND CONFIDENTIAL
 THE INFORMATION CONTAINED IN THIS DRAWING IS THE SOLE PROPERTY OF NAPOLEON/LYNX. ANY REPRODUCTION IN PART OR AS A WHOLE WITHOUT THE WRITTEN PERMISSION OF NAPOLEON/LYNX IS PROHIBITED.

Rev.
 06/08/15

WIRING DIAGRAM (FIELD)

LX-900 Wiring Connections

****Stop and Com must be jumpered when a 3-Button Wall Station is not Present**

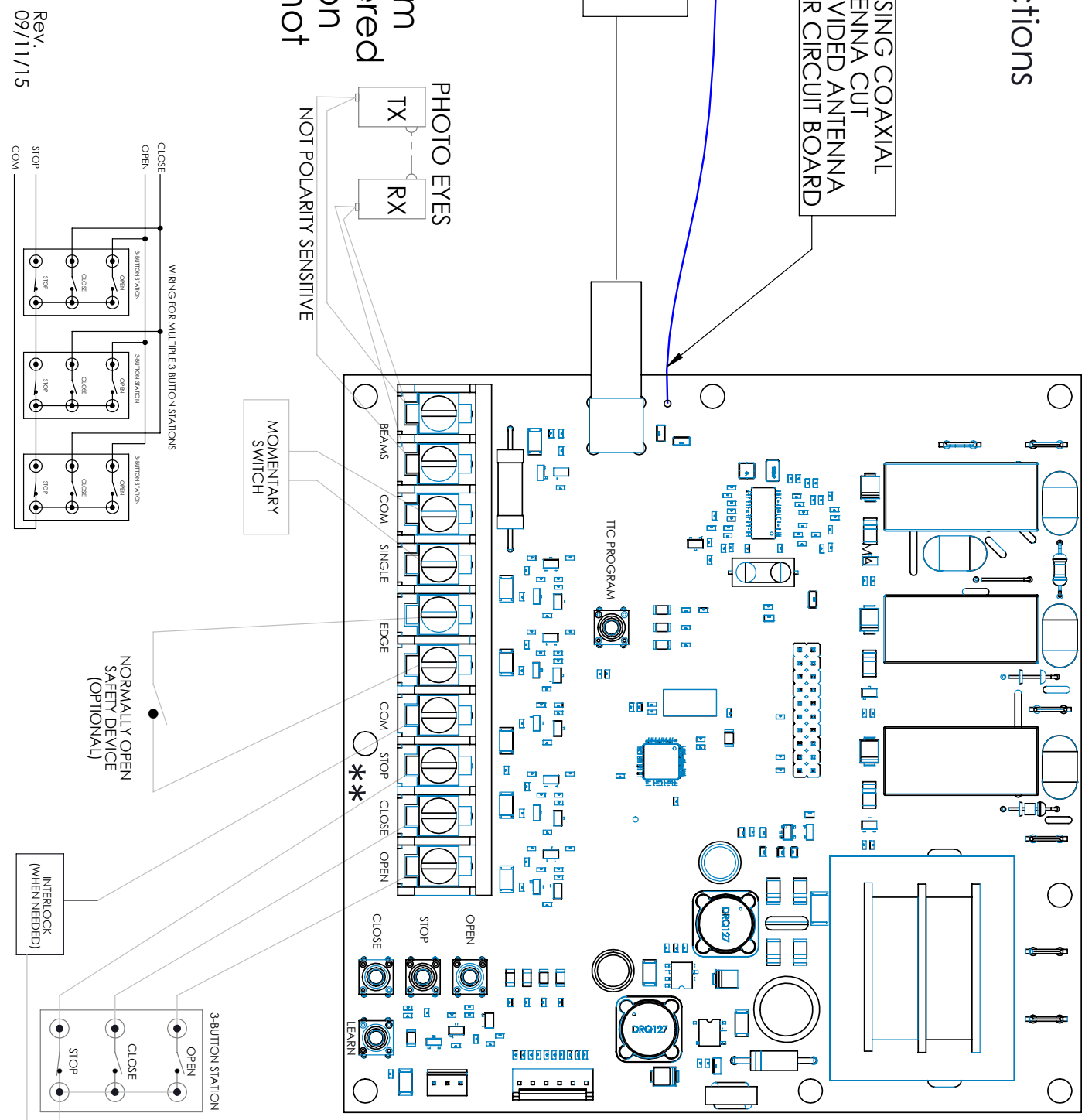
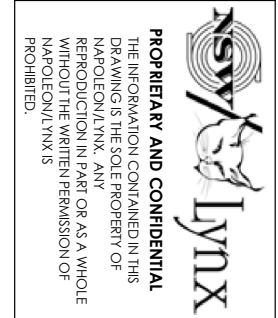

SHOP DRAWING

