

CHOICE SERIES

FOR STRENGTH TO STAND FIRM AGAINST HIGH WINDS

Safe-Way Garage Doors offers a full line of wind load rated doors designed and tested to meet Florida Building Code requirements. Made with rugged 25 gauge steel, featuring high-strength steel strut reinforcements, and available in 9 color options and 4 design options, Choice Series doors offer the perfect balance of strength and style.

FOR YOUR PEACE OF MIND.



SAFE-WAY
GARAGE DOORS
Make a Statement

Choice Series Wind Load Options

90 MPH	NON-INSULATED				
	Model	Embossment	Gauge	Warranty	Rating
	56C	Short, Raised Panel	25 gauge	15 year	90 MPH
	58C	Long, Raised Panel	25 gauge	15 year	90 MPH
	60C	Ribbed Steel	25 gauge	15 year	90 MPH
	INSULATED				
Model	Embossment	Gauge	Warranty	Rating	
57C	Short, Raised Panel	25 gauge	15 year	90 MPH	
59C	Long, Raised Panel	25 gauge	15 year	90 MPH	
61C	Ribbed Steel	25 gauge	15 year	90 MPH	

130 MPH	NON-INSULATED				
	Model	Embossment	Gauge	Warranty	Rating
	46G	Short, Raised Panel Carriage House	25 gauge	15 year	130 MPH
	48G	Long, Raised Panel Carriage House	25 gauge	15 year	130 MPH
	56G	Short, Raised Panel	25 gauge	15 year	130 MPH
	58G	Long, Raised Panel	25 gauge	15 year	130 MPH
	60G	Ribbed Steel	25 gauge	15 year	130 MPH
	INSULATED				
	Model	Embossment	Gauge	Warranty	Rating
	47G	Short, Raised Panel Carriage House	25 gauge	15 year	130 MPH
	49G	Long, Raised Panel Carriage House	25 gauge	15 year	130 MPH
	57G	Short, Raised Panel	25 gauge	15 year	130 MPH
	59G	Long, Raised Panel	25 gauge	15 year	130 MPH
	61G	Ribbed Steel	25 gauge	15 year	130 MPH

140 MPH	NON-INSULATED				
	Model	Embossment	Gauge	Warranty	Rating
	46H	Short, Raised Panel Carriage House	25 gauge	15 year	140 MPH
	48H	Long, Raised Panel Carriage House	25 gauge	15 year	140 MPH
	56H	Short, Raised Panel	25 gauge	15 year	140 MPH
	58H	Long, Raised Panel	25 gauge	15 year	140 MPH
	60H	Ribbed Steel	25 gauge	15 year	140 MPH
	INSULATED				
	Model	Embossment	Gauge	Warranty	Rating
	47H	Short, Raised Panel Carriage House	25 gauge	15 year	140 MPH
	49H	Long, Raised Panel Carriage House	25 gauge	15 year	140 MPH
	57H	Short, Raised Panel	25 gauge	15 year	140 MPH
	59H	Long, Raised Panel	25 gauge	15 year	140 MPH
	61H	Ribbed Steel	25 gauge	15 year	140 MPH

*Size availability by model may vary. Contact dealer for specific details.

Safe-Way Choice Series Wind Load Options doors use additional interior steel reinforcements with increased hardware and springing materials and have been designed and tested to meet code requirements.

CHOICE SERIES WIND LOAD OPTIONS

Wind Chamber Tested and Approved

Choice Series Wind Load Options doors are tested to ANSI/DASMA 108 in an approved wind chamber. Pounds per square foot (PSF) are converted to miles per hour windspeed based on ASCE standards for Safe-Way's Choice Series Wind Load Options C series of products. Testing is based on exposure category C with 30' or less of mean roof height. Design pressures are based on the required MPH windspeeds and test pressures are tested at 1.5 times the design pressure.

90 MPH	Door Size	Safe-Way "C" Products 90 MPH Design Load PSF
	9' x 7'	13.0 / -15.0
	12' x 7'	12.5 / -14.0
	16' x 7'	12.5 / -14.0
	18' x 12' 3"	12.5 / -14.0

130 MPH	Door Size	Safe-Way "G" Products 130 MPH Design Load PSF
	9' x 7'	19.9 / -22.4
	16' x 7'	19.3 / -21.6
	18' x 14'	17.5 / -19.3

140 MPH	Door Size	Safe-Way "H" Products 140 MPH Design Load PSF
	9' x 7'	23.9 / -26.1
	16' x 7'	22.9 / -25.1
18' x 14'	20.0 / -22.4	

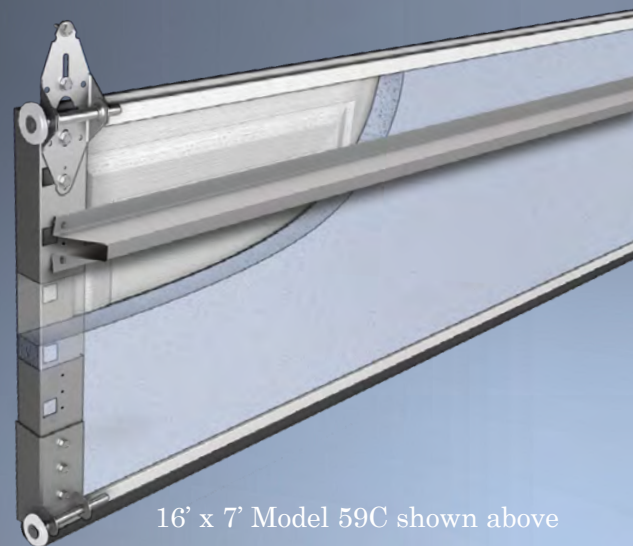

16' x 7' Model 59C shown above

Distributed by:



(877) 775-1670
FAX: (800) 276-7233

MANUFACTURING IN WARSAW, INDIANA
DISTRIBUTION CENTERS IN TENNESSEE AND MISSOURI

SAFEGWAYDOOR.COM

As Safe-Way Door constantly strives to improve our product, all specifications listed in this informative brochure are subject to change without notice or obligation. Printed color may vary from actual color, please check with your local dealer for color swatches.
10/2022